

Standard Lever with PTT Switch, Outboard



Optional SST Lever, Inboard



KE-4+ ELECTRONIC CONTROL SYSTEM

FOR BOATS WITH MECHANICAL THROTTLE AND MECHANICAL SHIFT

TECHNICAL DATA

The KE-4+ is a perfect answer to smooth and easy shift and throttle control suitable for most applications. Modern styling, various color/finish control head options, single to quad engine capability. Designed specifically to meet the performance, reliability endurance and aesthetic requirements of today's modern boats.

SPECIFICATIONS			
Maximum work load	343N (35 kgf)	Operating Thrust	147N (15 Kgf)
Output speed	50mm per second	Shift travel	40mm Max each (Fwd, Rev) - adjustable
Rated input voltages	12V/24V DC common mode	Operating environment	-68°F/-20°C to +167°F/+75°C
Current consumption	0.5A Max (while not in use)	Throttle travel	80mm Max -adjustable
Starting current - motor	16A Max (49N (5 Kgf) load)		

Optional hand held remote control



Twin control head

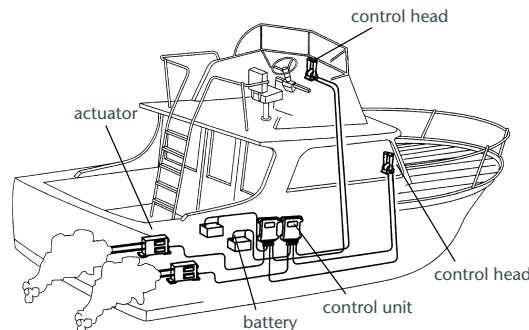

ISSUE DATE JUN-2011
NO. EC1usa

AT A GLANCE

FEATURES

- Designed for new installation or retrofit
- A new level of control performance for inboard, outboard or stern-drive engines; gas or diesel, 12V/24VDC common mode.
- Up to 4 stations
- Various color/finish control head options.
- Synchronization standard, 1 lever / 2 lever selection
- Neutral warm up function
- Complete self-diagnostic system
- Optional mechanical backup
- Adjustable shift pause and throttle delay
- Start in gear protection.
- Optional trolling system
- Remote hand held control optional. A great docking accessory
- Idle control option
- Standard outboard levers with ptt switch

Page 1 of 3



TECHNICAL DATA

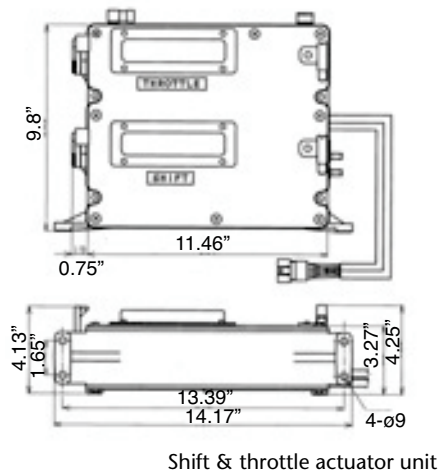
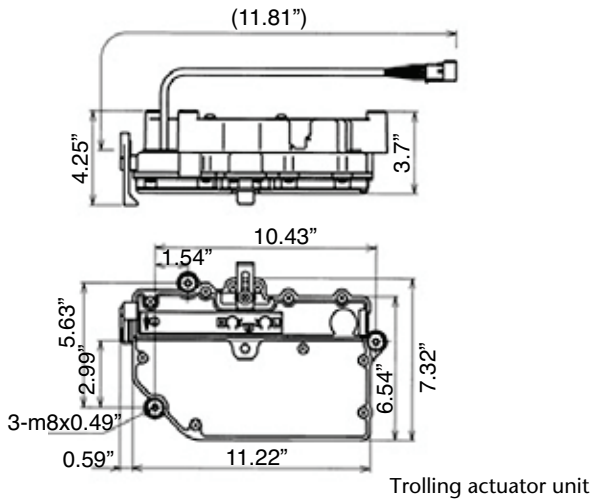
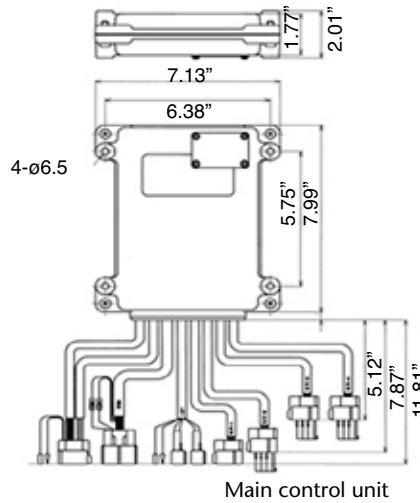
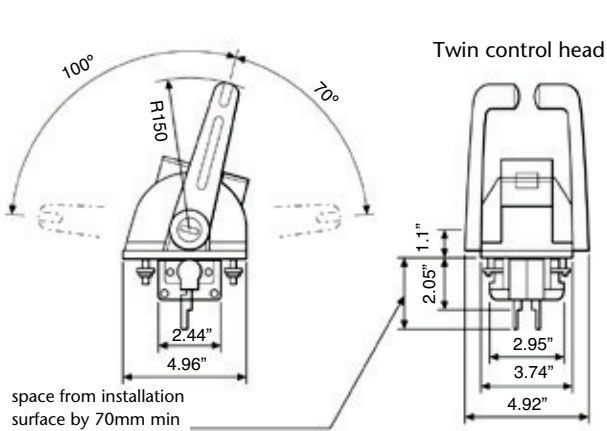

ISSUE DATE JUN-2011
NO. EC1usa

FEATURES

- Settings tool option via external PC
- Single to quad engine capability

ORDER INFORMATION

NO.	NAME	PART NO.	REQUIRED SINGLE ENGINE NO. OF STATIONS				DUAL ENGINES NO. OF STATIONS				TRIPLE ENGINES NO. OF STATIONS				QUAD ENGINES NO. OF STATIONS				NOTE	
			1	2	3	4	1	2	3	4	1	2	3	4	1	2	3	4		
1	Control head, Single without PTT PTT = trim/tilt switch with PTT SST = inboard style SST	NM1002-00																		
		NM1001-00	1	2	3	4	-	-	-	-	-	-	-	-	-	-	-	-		
		NM1003-00																		
2	Control head, Twin without PTT with PTT SST	NM1052-00	-	-	-	-	1	2	3	4	1	2	3	4	1	2	3	4		
		NM1051-00																		
		NM1053-00																		
3	Control unit 12V/24V D	NM1475-00	1	1	1	1	2	2	2	2	3	3	3	3	4	4	4	4		
4	Actuator	NM0183-00	1	1	1	1	2	2	2	2	3	3	3	3	4	4	4	4		



ORDER INFORMATION

NO.	NAME	PART NO.	REQUIRED SINGLE ENGINE NO. OF STATIONS				DUAL ENGINES NO. OF STATIONS				TRIPLE ENGINES NO. OF STATIONS				QUAD ENGINES NO. OF STATIONS				NOTE		
			1	2	3	4	1	2	3	4	1	2	3	4	1	2	3	4			
5	Bus Harness	2m	NM0649-02																	1m = 39 inches	
		4m	NM0649-04																		
		6m	NM0649-06																		
		8m	NM0649-08																		
		10m	NM0649-10																		
		12m	NM0649-12																		
		14m	NM0649-14	1	2	3	4	2	3	4	5	3	4	5	6	4	5	6	7		
		16m	NM0649-16																		
		18m	NM0649-18																		
		20m	NM0649-20																		
		24m	NM0649-24																		
30m	NM0649-30																				
40m	NM0649-40																				
50m	NM0649-50																				
6	Harness Power supply	5m 10m	NM0414-28 NM0414-33	2	2	2	2	4	4	4	4	6	6	6	6	8	8	8	8		
7	T-Harness (R/C-1) N		NM0647-09	1	1	1	1	1	1	1	1	1	1	1	1	1	1	1	1		
8	T-Harness (R/C)		NM0647-10	-	1	2	3	-	1	2	3	-	1	2	3	-	1	2	3		
9	T-Harness (Single)		NM0647-11	1	1	1	1	-	-	-	-	-	-	-	-	-	-	-	-		
10	T-Harness (Port)		NM0647-12	-	-	-	-	1	1	1	1	1	1	1	1	1	1	1	1		
11	T-Harness (STBD)		NM0647-13	-	-	-	-	1	1	1	1	1	1	1	1	1	1	1	1		
12	T-Harness (Center)		NM0647-14	-	-	-	-	-	-	-	-	1	1	1	1	1	1	1	1		
13	T-Harness (Center STBD)		NM0647-15	-	-	-	-	-	-	-	-	-	-	-	-	1	1	1	1		
14	Triple Switch		NJ0767-00	-	-	-	-	-	-	-	-	1	2	3	4	-	-	-	-		
15	Quad Switch		NJ0768-00	-	-	-	-	-	-	-	-	-	-	-	-	1	2	3	4		
16	Circuit breaker 20A		NJ0514-00	2	2	2	2	4	4	4	4	6	6	6	6	8	8	8	8	Optional	
17	Buzzer 24V model 12V model		NJ0515-00 NJ0596-00	1	2	3	4	2	4	6	8	1	2	3	4	1	2	3	4	Optional	
18	Idle Switch		NJ0765-00	1	2	3	4	1	2	3	4	1	2	3	4	1	2	3	4	Optional	
19	SW Extn Harness		NM0647-08	1	2	3	4	1	2	3	4	1	2	3	4	1	2	3	4	Optional	
20	Cable		33C Style CCX633XX TFXtreme	2	2	2	2	4	4	4	4	6	6	6	6	8	8	8	8	Specify the length CCX633XX Recommended	

XX = Length in feet

MECHANICAL BACK-UP OPTION											
10	Mechanical control head	Use standard control head	1	1	1	1	2	2	2	2	Option
11	Cable for manual operation	33C Style	2	2	2	2	4	4	4	4	Option, Specify the length

1 meter = approx. 39 Inches

OPTION	PART NO.
Hand Held Remote Control	See Teleflex Marine website for hand held instruction manual

ISSUE DATE JUN-2011
NO. EC1usa

Page 3 of 3



KE-4⁺

ELECTRONIC CONTROL SYSTEM

INSTRUCTION MANUAL

TABLE OF CONTENTS

INTRODUCTION	1
SAFETY PRECAUTIONS	1
INSTALLATION / REPAIR	1
PRODUCT COMPLIANCE	2
PRODUCT SPECIFICATIONS	2
PRODUCT FUNCTIONS	3
SINGLE ENGINE CONFIGURATION	4
→COMPONENTS LIST	5
DUAL ENGINE CONFIGURATION	6
→COMPONENTS LIST	7
TRIPLE ENGINE CONFIGURATION	8
→COMPONENTS LIST	9
QUAD ENGINE CONFIGURATION	10
→COMPONENTS LIST	11
CONTROL UNIT DETAILS	12
CONTROL HEAD DETAILS	13
ACTUATOR DETAILS	14
KE SYSTEM OPERATION	15
Initial Power ON & Control Head Lever Operation	15
Neutral Throttle Operation	16
Station Transfer	16
Synchronization Operation	16
DETERMINATION OF CABLE LENGTH	17
INSTALLING THE CONTROL HEAD	18
INSTALLING THE CONTROL UNIT	19
INSTALLING THE ACTUATOR	20
CONNECTING CONTROL HEAD AND CONTROL UNIT	21
CONNECTING ACTUATOR AND CONTROL UNIT	22
CONNECTING SIGP: START-IN-GEAR PROTECTION	23
CONNECTING POWER	24
CONNECTING THE SYNCHRONIZATION CIRCUIT	25
CONNECTING THE DIM HARNESS (OPTION)	26
CONNECTING BUZZER (OPTION)	27
CONNECTING TRIM CIRCUIT (OPTION)	28
CONNECTING IDLE SWITCH (OPTION)	29
CONNECTING TRIPLE SWITCH (OPTION)	30
CONNECTING QUAD SWITCH (OPTION)	31
PUSH-PULL CABLE INSTALLATION	32

TABLE OF CONTENTS (continued)

ADJUSTING THE CONTROL UNIT	34
● shift mode	34
● shift stroke: forward	34
● shift stroke: reverse	35
● throttle mode	35
● forward throttle stroke	35
● reverse throttle stroke	36
● synchronization configuration	36
● forward throttle opening	36
● reverse throttle opening	36
● throttle delay	37
● shift pause	37
● triple & quad engine configuration (supplemental info)	37
● settings tool enable	37
OPERATION CHECK	38
● Shift and throttle operation check	38
● Confirmation of engine start	38
MANUAL OPERATION METHOD (OPTION)	39
ALARM CODES	40
TROUBLESHOOTING	42
MAINTENANCE AND SERVICE	43
CONTROL HEAD TEMPLATE	44
CONTROL UNIT TEMPLATE	45
IDLE / TRIPLE / QUAD SWITCH TEMPLATE	46

INTRODUCTION

This manual has been prepared to ensure the correct operation of the standard configuration KE-4+ electronic remote control system. Be sure to read through this manual to understand the how system functions. Always keep the manual within your reach during operation. If your KE-4+ system also includes trolling control or handheld control options, please also refer to those additional manuals.

The KE-4+ system controls the shift (gear) and throttle (governor) of the vessel. It is recommended therefore to also read the instruction manuals of the vessel's engine and marine gear.

The specifications may be subject to change without notice (for upgrades), resulting in differences between the content of the manual and the product. In case of ambiguity or questions concerning the product or the manual, consult with your dealer.

SAFETY PRECAUTIONS

This manual contains precautions under the following headers, which, if not observed, could result in personal injury or damage to property. Pay particular attention to these precautions.



Failure to comply with a Warning may result in an accident causing death or serious injury.



Failure to comply with a Caution may result in an accident causing light injury or damage to the product or properties.

INSTALLATION / REPAIR

The installation of this product must be performed following all applicable installation and safety codes.

Only authorized personnel should perform disassembly and repair of this product; otherwise the warranty will be voided.

PRODUCT COMPLIANCE

1. EUROPEAN UNION



RECREATIONAL CRAFT DIRECTIVE
EMC DIRECTIVE

2. USCG

This control system provides start-in-gear protection meeting USCG requirements of 33 CFR Part 183, Subpart L.

3. ABYC, ISO

This control system meets applicable ABYC & ISO standards.

PRODUCT SPECIFICATIONS

1. Electrical Performance

- Supply voltage: DC 9V to 30V (12V/24VDC common mode)
- Max. current of actuator: 16A or less (at 49N{5kgf} · 11lbf load)
- Current consumption (stand-by): 0.5A or less

2. Mechanical Performance (Actuator)

- Thrust
- Operating thrust : 147N {15kgf} · 33 lbf
- Constraint load : 343N {35kgf} · 77 lbf
- Stroke
- Shift: Forward or Reverse stroke (can be set separately) 26 / 30 / 34 / 40 mm
- Throttle: 80mm MAX.

3. Temperature Range

- Operating temperature: $-20^{\circ}\text{C} \sim +75^{\circ}\text{C}$
- Storage temperature : $-40^{\circ}\text{C} \sim +100^{\circ}\text{C}$

PRODUCT FUNCTIONS

The KE-4+ electronic remote control system is capable of the following functions.

1. Main Functions

- Shift: Control head lever allows Forward/Neutral/Reverse operations of the vessel
- Throttle: Control head lever allows the acceleration & deceleration operations of the vessel
- Neutral throttle: Provides throttle only operation in order to warm up the engine
- Control Station Select: Allows transfer from one control station to another by pressing the SEL button on any control head; up to 4 control head stations are available
- Synch: Allows multi-engine speed synchronization by pressing the SYNC button on any control head; single lever synch and dual lever synch modes are available
- SIGP: Enables engine start up only when the vessel is in the neutral position; a safety feature
- Actuator settings: Allows various settings for actuator operation such as shift & throttle modes, push-pull cable stroke distances, etc. in order to match the KE-4+ system actuator outputs with a variety of engine and gearbox configurations. Settings are adjusted via the DIP switches accessible on the control unit.
- Alarm Codes: System errors are automatically detected and indicated via flashing LED-s on the control head; the last error code will also be displayed on the control unit alphanumeric display

The following options can also be added to the KE-4+ electronic remote control system.

2. Optional Functions

- Dim display: Decreases brightness of the LED on the control head during nighttime
- Buzzer: Combines an audio alarm to LED alarm codes
- Trim Circuit (for outboards): Master trim control switch available in the handle of the control head lever; in addition, circuit harness to connect to panel trim control switches for individual engine trim control in the case of multiple engines
- Idle control: Provides idle control of the engines via a 2-button switch / 1-LED display; incrementally increases throttle up to 20% of max. throttle
- Triple engine control: Provides options for control of center engine actuator from the port lever via a 1-button switch / 2-LED display
- Quadruple engine control: Provides options for control of inside engine actuators (center-port & center-starboard) and outside engines (port & starboard) via a 1-button switch / 2-LED display
- Mechanical backup: In case of system failure, enables manual operation of actuator lever via a mechanical control head
- Trolling control: Allows trolling speed control of the vessel via a 2-button switch / 1-LED display plus trolling unit & trolling actuators
- Handheld control: Provides a handheld / mobile version of the control head to be added to the system; attached to the main system via long harnesses.
- Settings Tool: Software version of the actuator settings; requires a laptop connection. Can be used as a substitute for the DIP switch procedure described in the main functions; particularly useful for multi-vessel settings management.

SINGLE ENGINE CONFIGURATION

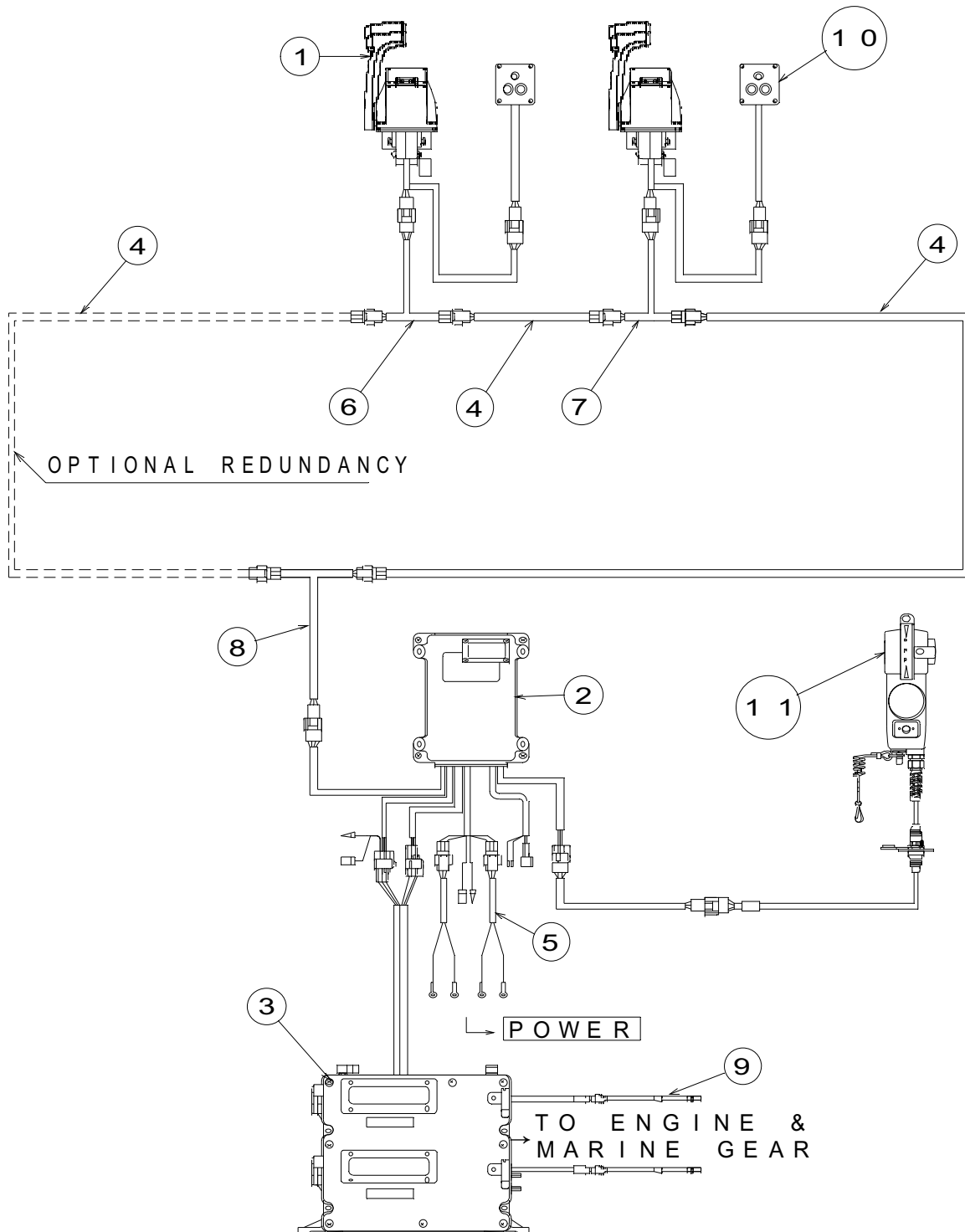

Note: The figure above is an example of a single engine / two control stations system with optional idle control switches and optional handheld control.

COMPONENTS LIST

KE-4+ Component Parts List (Single)		Required Quantity				
		Single Engine			4	
		No. of stations				
Description	Part number	1	2	3	4	
① Control Head, Single w/o PTT	NM1002-00					
<i>PTT = power trim/tilt switch (o/b style) w/ PTT</i>	NM1001-00	1	2	3	4	
<i>SST = stainless steel, (i/b style)</i> SST	NM1003-00					
② Control unit 12V/24V	NM1475-00				1	
③ Actuator	NM0183-00				1	
④ Bus Harness 2m 4m 6m 1m = 39 inches  CAUTION Bus harness should not exceed 80m in total length; otherwise system performance could degrade.	NM0649-02					
	NM0649-04					
	NM0649-06					
	NM0649-08					
	NM0649-10					
	NM0649-12					
	NM0649-14	1	2	3	4	
	NM0649-16					
	NM0649-18					
	NM0649-20					
	NM0649-24					
	NM0649-30					
	40m	NM0649-40				
	50m	NM0649-50				
⑤ Harness Power Supply	5m NM0414-28				2	
	10m NM0414-33					
⑥ T-harness (R/C-1)	NM0647-09				1	
⑦ T-harness (R/C)	NM0647-10	-	1	2	3	
⑧ T-harness (SINGLE)	NM0647-11				1	
⑨ Push - pull cable	TFXtreme, 33HPC				2	
⑩ Idle Switch (optional)	NJ0765-00	1	2	3	4	
⑪ Handheld control (optional)	Refer to handheld manual					
Circuit Breaker (optional)	20A NJ0514-00				2	
Buzzer (optional)	12V NJ0596-00				4	
	24V NJ0515-00	1	2	3		
SW extension harness (optional)	NM0647-08	1	2	3	4	

Note: Refer to previous page for balloon references and system configuration.

DUAL ENGINE CONFIGURATION

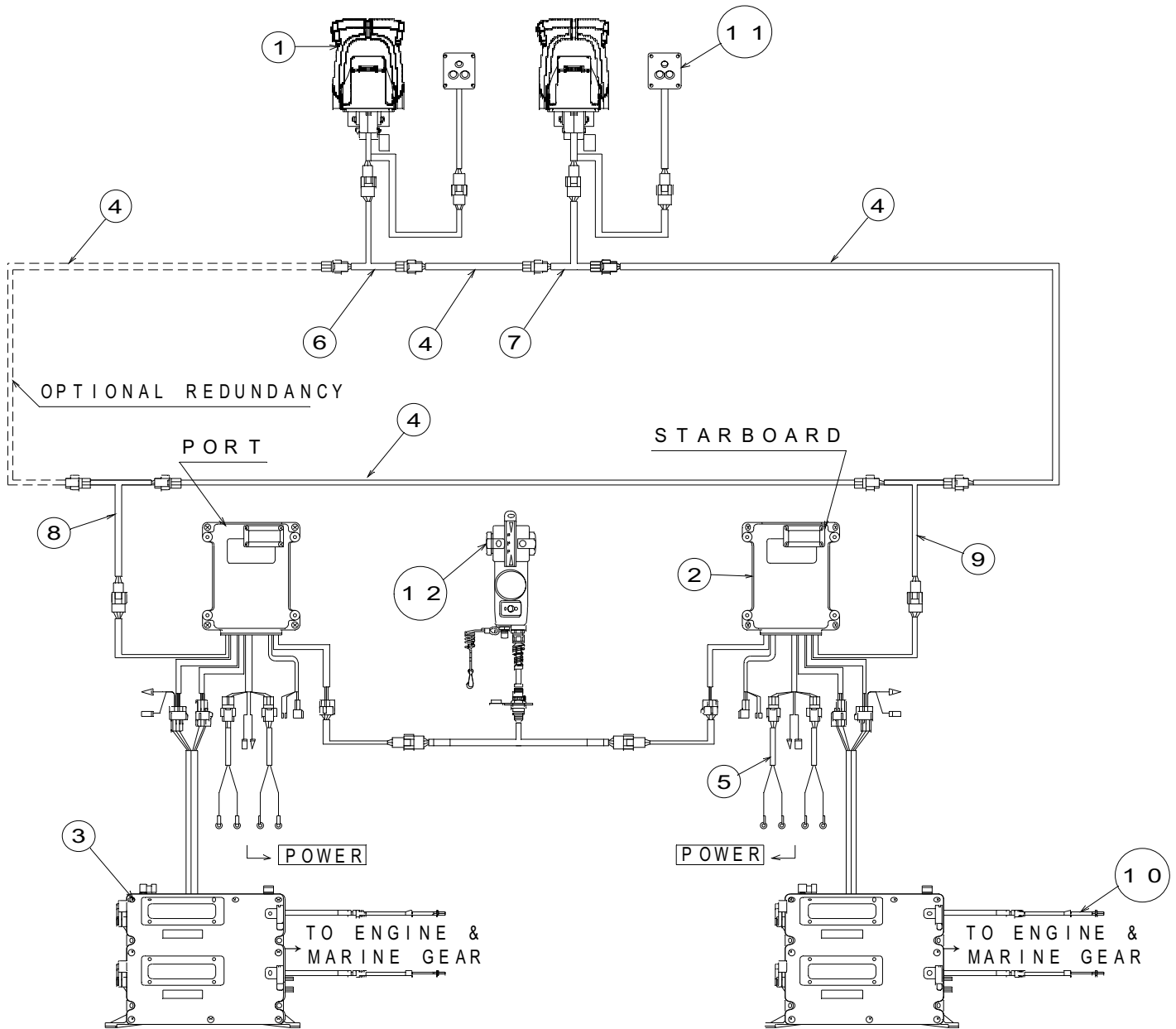

Note: The figure above is an example of a two engines / two control stations system with optional idle control switches and optional handheld control.

COMPONENTS LIST

KE-4+ Component Parts List (Dual)		Required Quantity			
		Dual Engine			
		No. of stations			
Description	Part number	1	2	3	4
① Control Head, Twin w/ PTT	NM1051-00				4
<i>PTT = power trim/tilt switch (o/b style)w/o PTT</i>	NM1052-00	1	2	3	4
<i>SST = stainless steel, (i/b style)</i> SST	NM1053-00				
② Control unit 12V/24V	NM1475-00	2			
③ Actuator	NM0183-00	2			
④ Bus Harness 2m 4m 6m 8m 1m = 39 inches  CAUTION Bus harness should not exceed 80m in total length; otherwise system performance could degrade.	NM0649-02				5
	NM0649-04				
	NM0649-06				
	NM0649-08				
	NM0649-10				
	NM0649-12				
	NM0649-14	2	3	4	
	NM0649-16				
	NM0649-18				
	NM0649-20				
	NM0649-24				
	NM0649-30				
	NM0649-40				
50m	NM0649-50				
⑤ Harness Power Supply	5m	4			
	10m				
⑥ T-harness (R/C-1)	NM0647-09	1			
⑦ T-harness (R/C)	NM0647-10	-	1	2	3
⑧ T-harness (PORT)	NM0647-12	1			
⑨ T-harness (STBD)	NM0647-13	1			
⑩ Push - pull cable	TFXtreme, 33HPC	4			
⑪ Idle Switch (optional)	NJ0765-00	1	2	3	4
⑫ Handheld control (optional)	Refer to handheld control manual				
Circuit Breaker (optional)	20A	4			
Buzzer (optional)	12V	4			
	24V				
SW extension harness (optional)	NM0647-08	1	2	3	4
Trim circuit harness (optional)	NJ0772-00	1	2	3	4

Note: Refer to previous page for balloon references and system configuration.

TRIPLE ENGINE CONFIGURATION

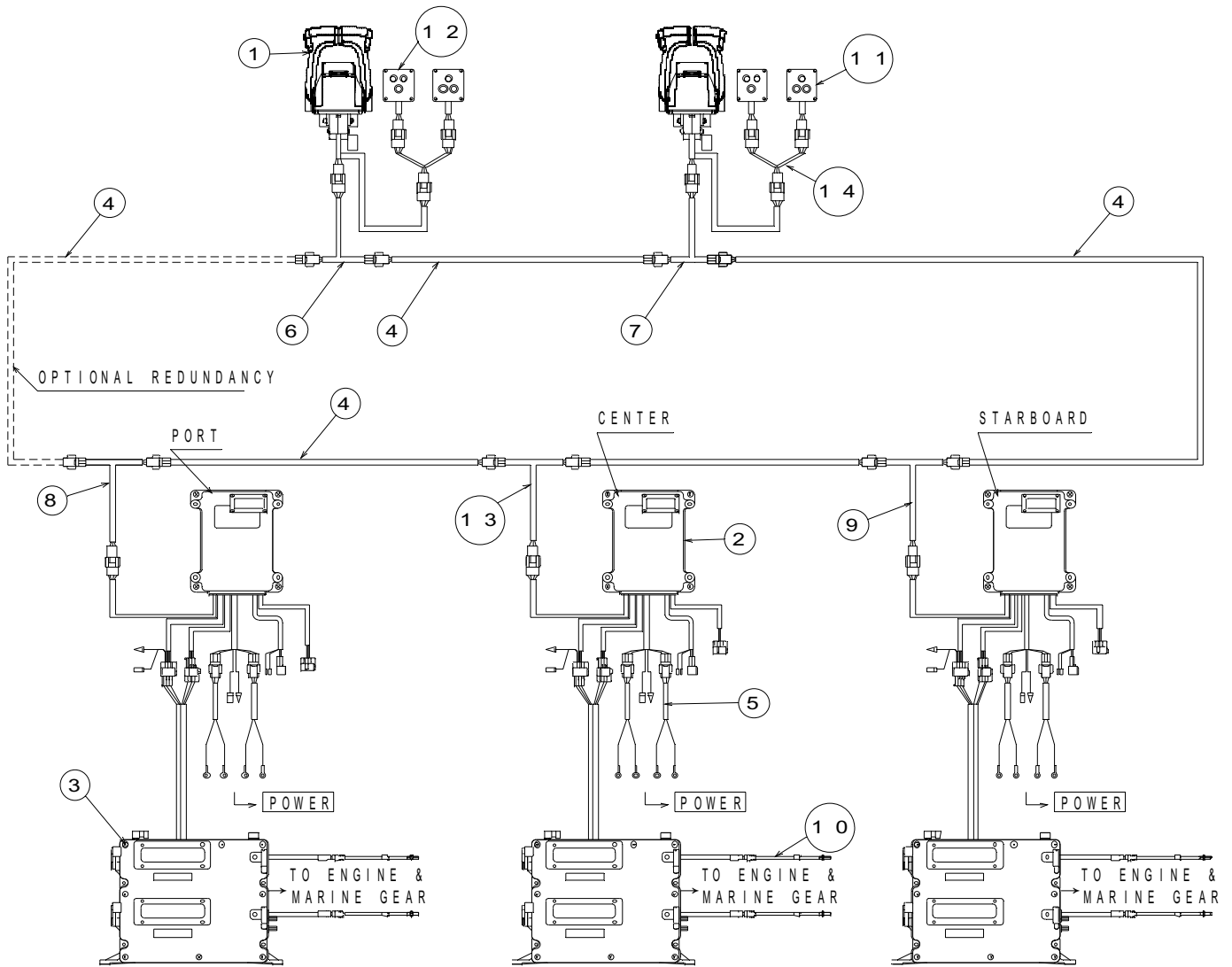

Note: The figure above is an example of a three engines / two control stations system with optional idle control switch.

COMPONENTS LIST

KE-4+ Component Parts List (Triple)		Required Quantity			
		Triple Engine			
		No. of stations			
Description	Part number	1	2	3	4
① Control Head, Twin	w/ PTT NM1051-00	1	2	3	4
<i>PTT = power trim/tilt switch (o/b style)</i>	w/o PTT NM1052-00				
<i>SST = stainless steel, (i/b style)</i>	SST NM1053-00				
② Control unit 12V/24V	NM1475-00	3			
③ Actuator	NM0183-00	3			
④ Bus Harness 2m 4m 6m 8m 10m 12m 14m 16m 18m 20m 24m 30m 40m 50m  CAUTION Bus harness should not exceed 80m in total length; otherwise system performance could degrade.	NM0649-02	3	4	5	6
	NM0649-04				
	NM0649-06				
	NM0649-08				
	NM0649-10				
	NM0649-12				
	NM0649-14				
	NM0649-16				
	NM0649-18				
	NM0649-20				
	NM0649-24				
	NM0649-30				
	NM0649-40				
	NM0649-50				
⑤ Harness Power Supply	5m NM0414-28	6			
	10m NM0414-33				
⑥ T-harness (R/C-1)	NM0647-09	1			
⑦ T-harness (R/C)	NM0647-10	-	1	2	3
⑧ T-harness (PORT)	NM0647-12	1			
⑨ T-harness (STBD)	NM0647-13	1			
⑩ Push - pull cable	TFXtreme, 33HPC	6			
⑪ Idle Switch (optional)	NJ0765-00	1	2	3	4
⑫ Triple Switch	NJ0767-00	1	2	3	4
⑬ T-harness (CENTER)	NM0647-14	1			
Circuit Breaker (optional)	20A NJ0514-00	6			
Buzzer (optional)	12V NJ0596-00	1	2	3	4
	24V NJ0515-00				
⑭ SW extension harness (optional)	NM0647-08	1	2	3	4
Trim circuit harness (optional)	NJ0772-00	2	4	6	8

Note: Refer to previous page for balloon references and system configuration.

QUAD ENGINE CONFIGURATION

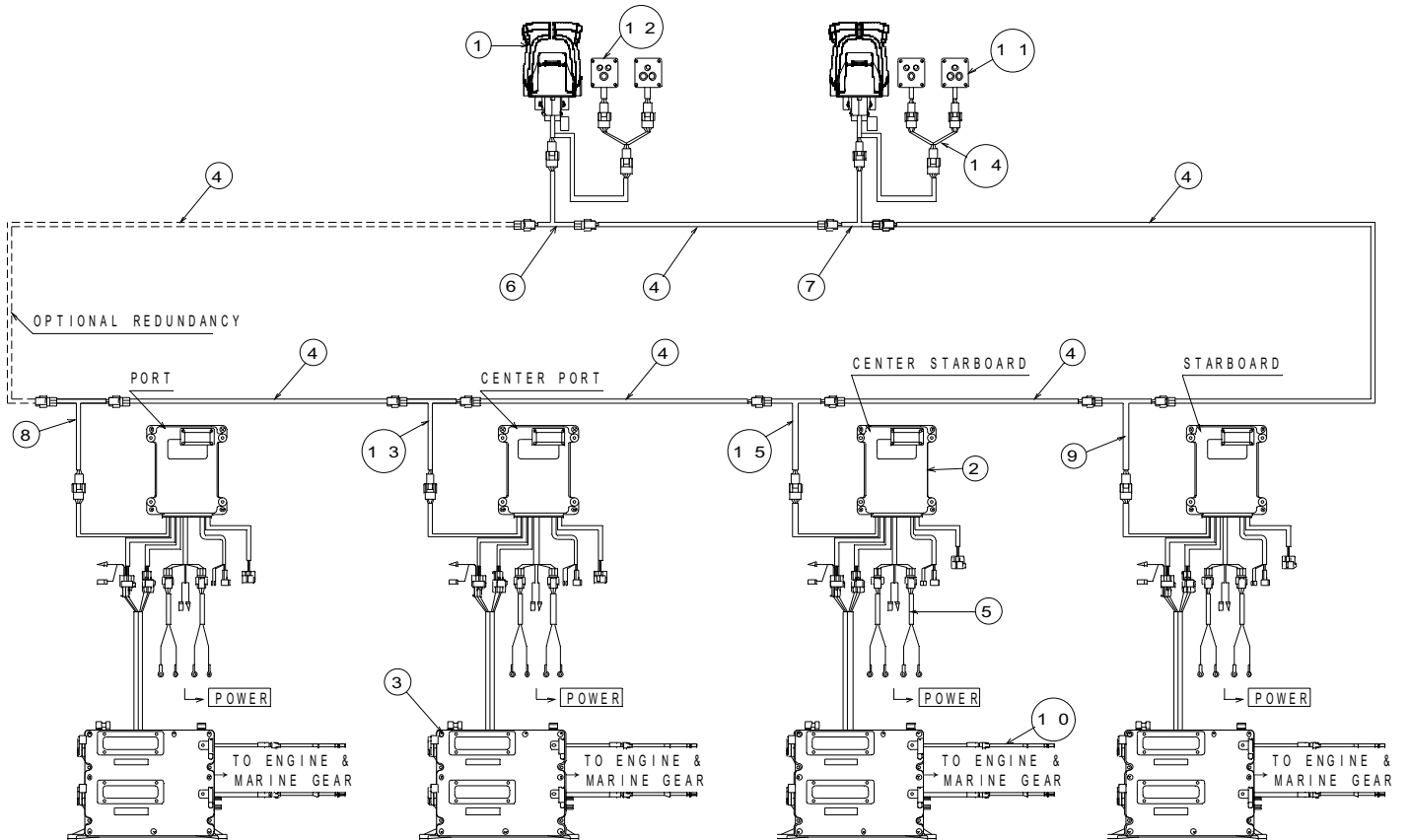

Note: The figure above is an example of a four engines / two control stations system with optional idle control switch.

COMPONENTS LIST

KE-4+ Component Parts List (Quad)		Required Quantity			
		Quad Engine			
		No. of stations			
Description	Part number	1	2	3	4
① Control Head, Twin	w/ PTT NM1051-00				
<i>PTT = power trim/tilt switch (o/b style)</i>	w/o PTT NM1052-00	1	2	3	4
<i>SST = stainless steel, (i/b style)</i>	SST NM1053-00				
② Control unit 12V/24V	NM1475-00	4			
③ Actuator	NM0183-00	4			
④ Bus Harness 1m = 39 inches  CAUTION Bus harness should not exceed 80m in total length; otherwise system performance could degrade.	2m NM0649-02	4	5	6	7
	4m NM0649-04				
	6m NM0649-06				
	8m NM0649-08				
	10m NM0649-10				
	12m NM0649-12				
	14m NM0649-14				
	16m NM0649-16				
	18m NM0649-18				
	20m NM0649-20				
	24m NM0649-24				
	30m NM0649-30				
	40m NM0649-40				
50m NM0649-50					
⑤ Harness Power Supply	5m NM0414-28	8			
	10m NM0414-33				
⑥ T-harness (R/C-1)	NM0647-09	1			
⑦ T-harness (R/C)	NM0647-10	-	1	2	3
⑧ T-harness (PORT)	NM0647-12	1			
⑨ T-harness (STBD)	NM0647-13	1			
⑩ Push - pull cable	TFXtreme, 33HPC	8			
⑪ Idle Switch (optional)	NJ0765-00	1	2	3	4
⑫ Quad Switch	NJ0768-00	1	2	3	4
⑬ T-harness (CENTER)	NM0647-14	1			
Circuit Breaker (optional)	20A NJ0514-00	8			
Buzzer (optional)	12V NJ0596-00	1	2	3	4
	24V NJ0515-00				
⑭ SW extension harness (optional)	NM0647-08	1	2	3	4
⑮ T-harness (CENTER-STBD)	NM0647-15	1			
Trim circuit harness (optional)	NJ0772-00	2	4	6	8

Note: Refer to previous page for balloon references and system configuration

CONTROL UNIT

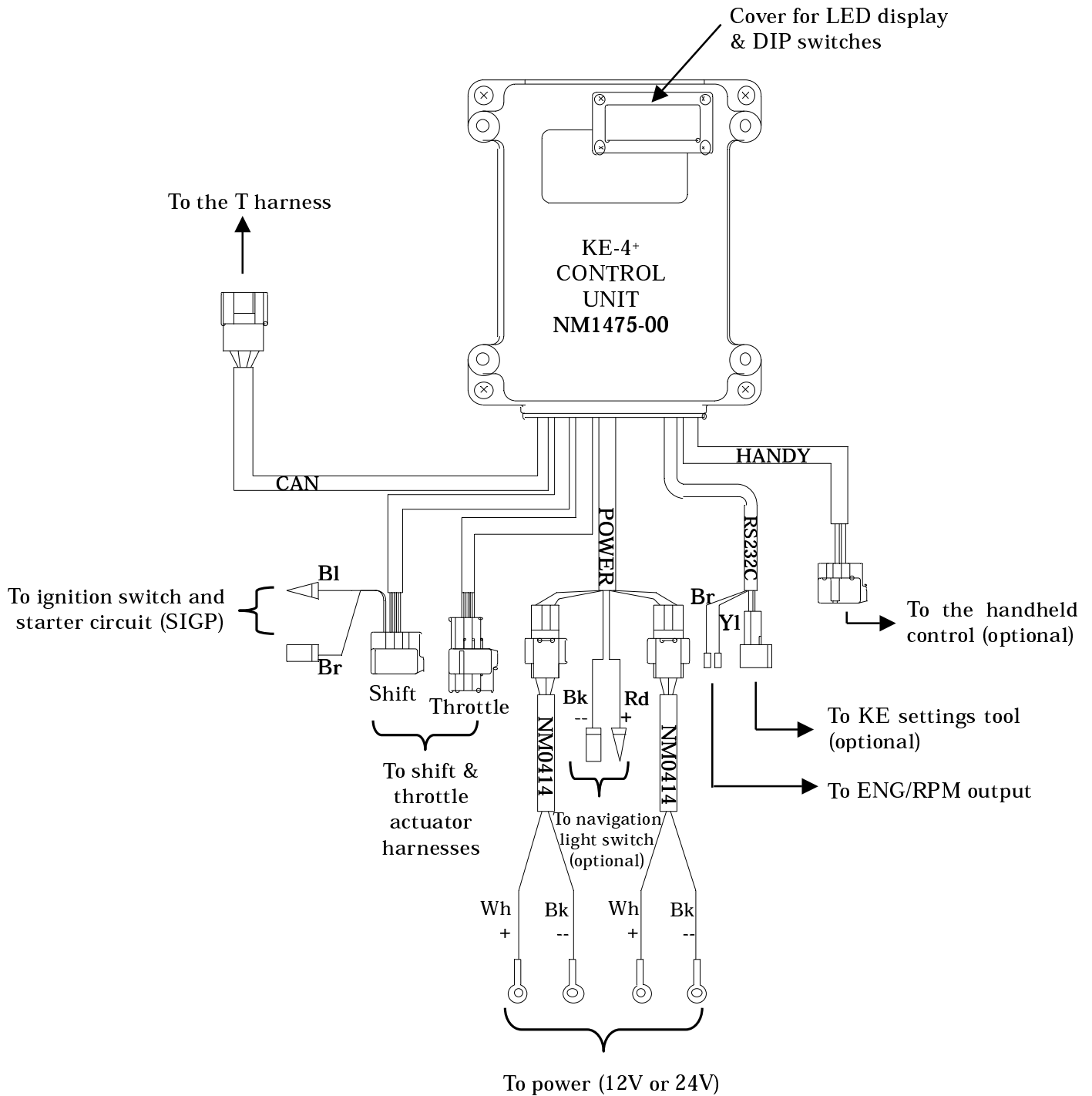

Note: The Control Unit is a common-mode two type that can be used with either 24V or 12V power.

CONTROL HEAD

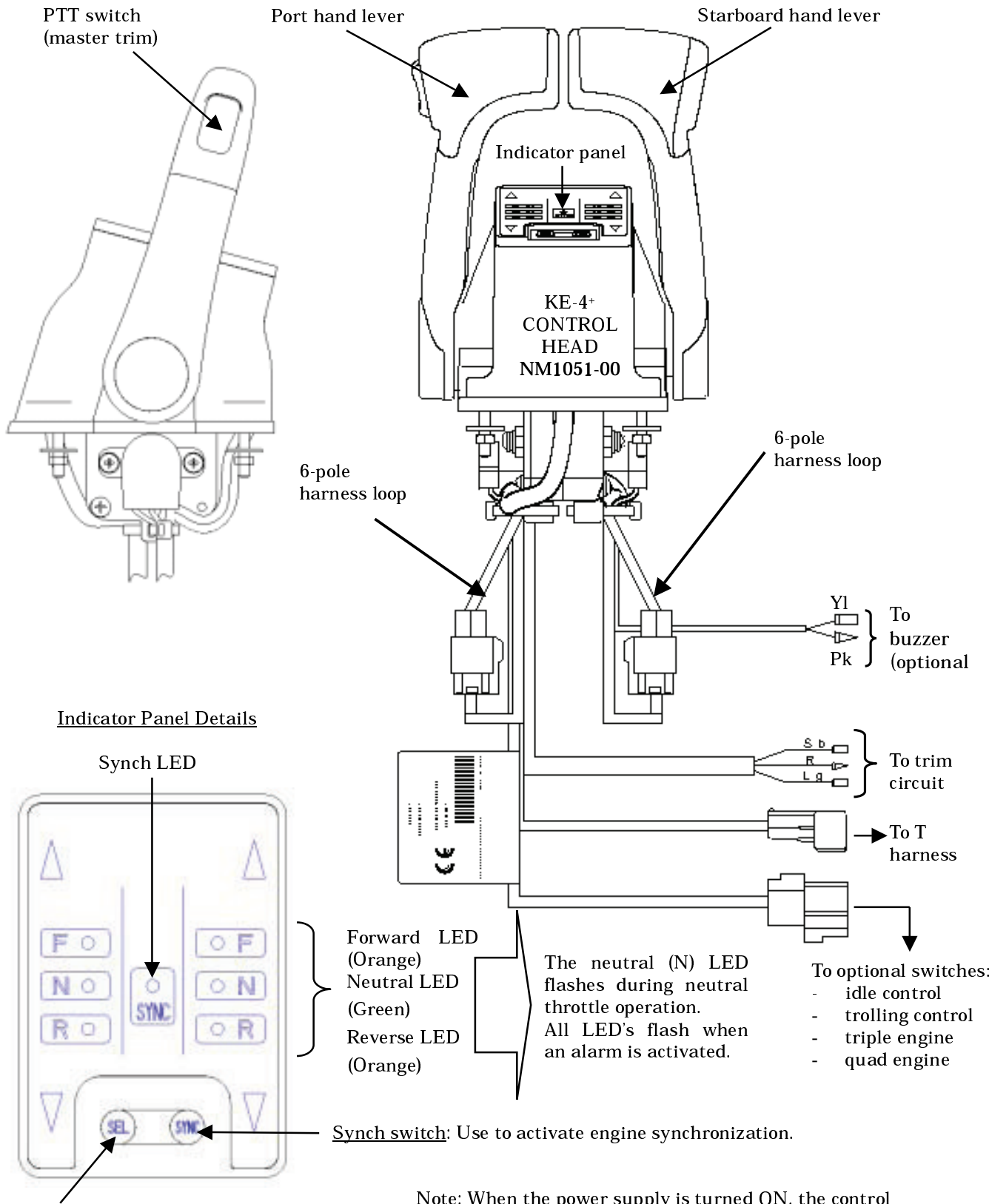

Select switch: Press to select station, set/cancel neutral throttle operation, & stop the buzzer.

Synch switch: Use to activate engine synchronization.

Note: When the power supply is turned ON, the control head connected to R/C-1 T-harness is the first one to become operative. Be sure to connect a control head to R/C-1 T-harness.

ACTUATOR

 **WARNING**

Operate the Selector Knob only in case of emergency (mechanical backup)

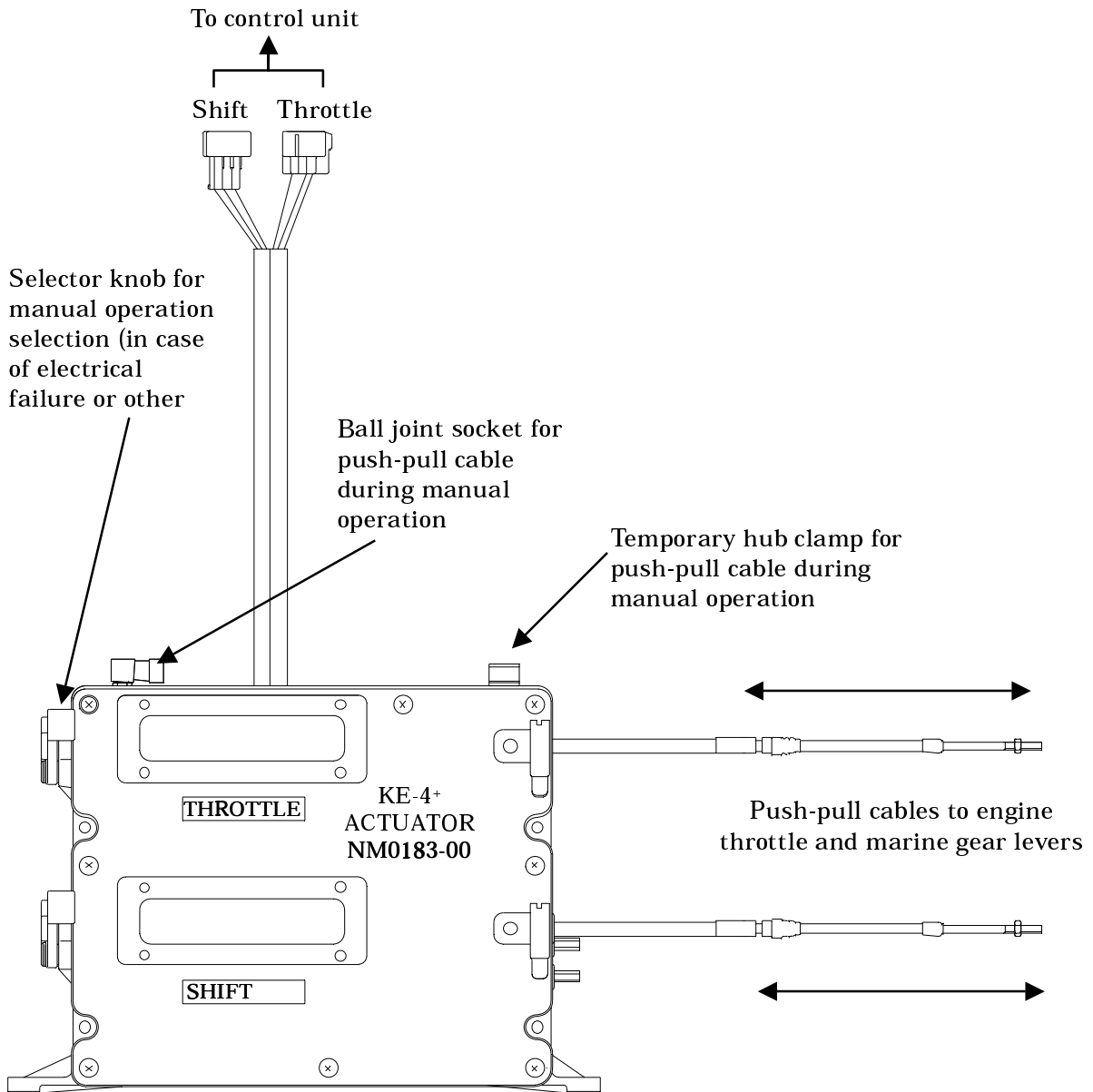

Note: The actuator assembly includes both throttle and shift actuators